

**FREEWAY MAINTENANCE AGREEMENT
WITH
CITY OF TEMECULA**

THIS AGREEMENT is made effective this _____ day of _____, 20__, by and between the State of California, acting by and through the Department of Transportation, hereinafter referred to as "STATE" and the CITY of Temecula; hereinafter referred to as "CITY" and collectively referred to as "PARTIES."

SECTION I

RECITALS

1. On July 13, 2010 a Freeway Agreement was executed between CITY and STATE, wherein the PARTIES consented to certain adjustments of the local street and road system required for the development of that portion of STATE Interstate 15 (I-15), declared a freeway, within the jurisdictional limits of the CITY.
2. Recent adjustments to said freeway have now been completed, or are nearing completion, and the PARTIES hereto mutually desire to identify the maintenance responsibilities of the CITY for areas lying within those modified freeway limits hereinafter referred to as "PROJECT."
3. There is an existing Freeway Maintenance Agreement(s), with CITY dated July 31, 1990. This Agreement is meant to replace or supersede the earlier agreement.

NOW THEREFORE IT IS AGREED:

SECTION II

AGREEMENT

1. PARTIES agree this Agreement shall supersede in its entirety the said Freeway Maintenance Agreement executed by PARTIES on July 31, 1990.
2. Pursuant to Section 6 of the July 13, 2010 Freeway Agreement, CITY has resumed or will resume control and maintenance over each of the relocated or reconstructed CITY roads, frontage roads, and other STATE constructed local roads, except for any portion which is adopted by STATE as a part of the freeway proper.
3. The degree or extent of maintenance work to be performed, and the standards therefore, shall be in accordance with the provisions of Section 27 of the Streets and Highways Code and the then current edition of the State Maintenance Manual.

4. CITY agrees to continue their control and maintenance of each of the affected relocated or reconstructed CITY streets and roads as shown on that attached hereto, Exhibit A and made a part hereof by this reference.
5. When another planned future improvement has been constructed and/or a minor revision has been affected within the limits of the freeway herein described which will affect the PARTIES' maintenance responsibility as described herein, and there is mutual agreement on a change in the maintenance responsibilities between PARTIES, the PARTIES can revise the Exhibit A by a mutual written execution of each of the exhibits.
6. CITY must obtain the necessary Encroachment Permits from STATE's District 08 Encroachment Permit Office prior to entering STATE right of way to perform CITY maintenance responsibilities. This permit will be issued at no cost to CITY.

7. VEHICULAR OVERCROSSINGS

7.1. CITY will maintain, at CITY expense, the deck wearing surface and structural drainage system (and shall perform such work as may be necessary to ensure an impervious and/or otherwise suitable surface) and all portions of the structure above the bridge deck, including, but without limitation, lighting installations, as well as all traffic service facilities (sidewalks, signs, pavement markings, bridge rails, etc.) that may be required for the benefit or control of traffic using that overcrossing.

7.2. As directed by section 92.6 of the Streets and Highways Code, at locations determined by STATE, screening shall be placed on STATE freeway overpasses on which pedestrians are allowed. All screens installed under this program will be maintained by STATE, at STATE expense.

8. PEDESTRIAN/BICYCLE OVERCROSSINGS (non-vehicular) constructed as a permitted encroachment within STATE's right of way. CITY is solely responsible for, but not limited to, the structural adequacy, lighting, fencing, guard railing, drainage facilities, graffiti removal, sweeping and debris removal, signing, and striping, slope paving and delineation. CITY will maintain, at CITY expense, a safe facility for pedestrian and bicycle use along the entire length of the structure and the public use of the STATE highway beneath, by providing structure inspection, and structure maintenance.

9. VEHICULAR AND PEDESTRIAN UNDERCROSSINGS

9.1. CITY will maintain the CITY paved roadway sections, including the traveled way, shoulders, curbs, sidewalks, wall surfaces (including eliminating graffiti),

drainage installations, lighting installations and traffic service facilities that may be required for the benefit or control of traffic using that undercrossing.

- 9.2. CITY will request STATE's District Encroachment Permit Engineer to issue the necessary Encroachment Permit for any proposed change in minimum vertical clearances between CITY roadway surface and the structure that results from modifications to the roadway (except when said modifications are made by STATE). If the planned modifications will result in a reduction in the minimum clearance within the traveled way, an estimate of the clearance reduction must be provided to STATE's Transportation Permit Engineer prior to starting work. Upon completion of that work, a vertical clearance diagram will be furnished to STATE's Transportation Permit Engineer that shows revised minimum clearances for all affected movements of traffic, both at the edges of the traveled way and at points of minimum clearance within the traveled way.

10. WALLS, SOUNDWALLS, AND COLUMNS – CITY is responsible for debris removal, cleaning, and painting to keep CITY's/CITY's side of any wall structure or column free of debris, dirt, and graffiti.

11. LANDSCAPED AREAS CITY is responsible for the maintenance of any plantings or other types of roadside improvements of PROJECT lying outside of the fenced area restricting walk-on access to the freeway.

12. INTERCHANGE OPERATION - It is STATE's responsibility to provide efficient operation of freeway interchanges, including ramp connections to local streets and roads.

13. ELECTRICALLY OPERATED TRAFFIC CONTROL DEVICES

13.1. The cost of installation, operation, maintenance, repairs, replacement and energy costs of safety lighting, traffic signals or other necessary electrically operated traffic control devices placed at interchanges of I-15 Freeway and at ramp connections to CITY streets and roads of I-15 shall be shared by the PARTIES as directed in the Shared Cost Electrical Cost Agreement amended August 1, 1999.

13.2. Timing of traffic signals, which shall be coordinated with CITY to the extent that no conflict is created with freeway operations, shall be the sole responsibility of STATE.

14. BICYCLE PATHS, LANES, AND CYCLE TRACKS constructed as permitted encroachments within STATE's right of way, CITY is solely responsible for all permitted improvements, including but not limited to the delineation, fencing,

guard railing, drainage facilities, slope and structural adequacy. CITY will maintain, at CITY expense, a safe facility for bicycle travel along the entire length of the path/lane/cycle track by providing sweeping and debris removal when necessary; and all signing and striping, and pavement markings required for the direction and operation of that non-motorized facility.

15. LEGAL RELATIONS AND RESPONSIBILITIES

15.1. Nothing within the provisions of this Agreement is intended to create duties or obligations to or rights in third parties not PARTIES to this Agreement or to affect the legal liability of a PARTY to the Agreement by imposing any standard of care with respect to the operation and maintenance of STATE highways and local facilities different from the standard of care imposed by law.

15.2. Neither CITY nor any officer or employee thereof is responsible for any injury, damage or liability occurring by reason of anything done or omitted to be done by STATE, under or in connection with any work, authority or jurisdiction conferred upon STATE arising under this Agreement. It is understood and agreed that STATE shall fully defend, indemnify and save harmless CITY and their officers and employees from all claims, suits or actions of every name, kind and description brought forth under, including, but not limited to, tortuous, contractual, inverse condemnation and other theories or assertions of liability occurring by reason of anything done or omitted to be done by STATE under this Agreement.

15.3. Neither STATE nor any officer or employee thereof is responsible for any injury, damage or liability occurring by reason of anything done or omitted to be done by CITY under or in connection with any work, authority or jurisdiction conferred upon CITY and arising under this Agreement. It is understood and agreed that CITY shall fully defend, indemnify and save harmless STATE and all of its officers and employees from all claims, suits or actions of every name, kind and description brought forth under, including, but not limited to, tortuous, contractual, inverse condemnation or other theories or assertions of liability occurring by reason of anything done or omitted to be done by CITY under this Agreement.

16. PREVAILING WAGES:

16.1. Labor Code Compliance- If the work performed under this Agreement is done under contract and falls within the Labor Code section 1720(a)(1) definition of a "public works" in that it is construction, alteration, demolition, installation, or repair; or maintenance work under Labor Code section 1771. CITY must conform to the provisions of Labor Code sections 1720 through 1815,

and all applicable provisions of California Code of Regulations found in Title 8, Chapter 8, Subchapter 3, Articles 1-7. CITY agrees to include prevailing wage requirements in its contracts for public works. Work performed by CITY's own forces is exempt from the Labor Code's Prevailing Wage requirements.

- 16.2. Requirements in Subcontracts - CITY shall require its contractors to include prevailing wage requirements in all subcontracts when the work to be performed by the subcontractor under this Agreement is a "public works" as defined in Labor Code Section 1720(a)(1) and Labor Code Section 1771. Subcontracts shall include all prevailing wage requirements set forth in CITY's contracts.

17.INSURANCE

- 17.1. SELF-INSURED- CITY is self-insured. CITY agrees to deliver evidence of self-insured coverage providing general liability insurance, coverage of bodily injury liability and property damage liability, naming STATE, its officers, agents and employees as the additional insured in an amount of \$1 million per occurrence and \$2 million in aggregate and \$5 million in excess. Coverage shall be evidenced by a certification of self-insurance letter ("Letter of Self-Insurance"), satisfactory to STATE, certifying that CITY meets the coverage requirements of this section. This Letter of Self-Insurance shall also identify the PROJECT location as depicted in EXHIBIT A. CITY shall deliver to STATE the Letter of Self-Insurance with a signed copy of this AGREEMENT. A copy of the executed Letter of Self-Insurance shall be attached hereto and incorporate as Exhibit B.

- 17.2. SELF-INSURED using Contractor – If the work performed under this AGREEMENT is done by CITY's contractor(s), CITY shall require its contractor(s) to maintain in force, during the term of this AGREEMENT, a policy of general liability insurance, including coverage of bodily injury liability and property damage liability, naming STATE, its officers, agents and employees as the additional insured in an amount of \$1 million per occurrence and \$2 million in aggregate and \$5 million in excess. Coverage shall be evidenced by a certificate of insurance in a form satisfactory to the STATE that shall be delivered to the STATE with a signed copy of this Agreement.

18. TERMINATION - This Agreement may be terminated by timely mutual written consent by PARTIES, and CITY's failure to comply with the provisions of this Agreement may be grounds for a Notice of Termination by STATE.

19. TERM OF AGREEMENT - This Agreement shall become effective on the date first shown on its face sheet and shall remain in full force and effect until amended or

terminated at any time upon mutual consent of the PARTIES or until terminated by STATE for cause.

PARTIES are empowered by Streets and Highways Code Section 114 and 130 to enter into this Agreement and have delegated to the undersigned the authority to execute this Agreement on behalf of the respective agencies and covenants to have followed all the necessary legal requirements to validly execute this Agreement.

IN WITNESS WHEREOF, PARTIES hereto have set their hands and seals the day and year first above written.

THE CITY OF TEMECULA

STATE OF CALIFORNIA
DEPARTMENT OF TRANSPORTATION

By: _____
Zak Schwank
Mayor

ATTEST:

By: _____
Randi Johl
City Clerk

By: _____
Jim A. Rogers
Deputy District Director
Maintenance District 08

By: _____
Peter Thorson
City Attorney

EXHIBIT A

(Plan map identifying the applicable STATE Routes (Freeway proper) and CITY road(s) and facilities)

DIST	COUNTY	ROUTE	POST MILE	SHEET No.	TOTAL SHEETS
08	RIV	15	3.5 / 7.2	1	6

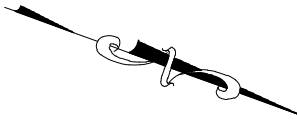

LOCATION 1 SHEET 2
TEMECULA PKWY / SR-79
PM 3.5

LOCATION 2 SHEET 3
SANTIAGO RD
OC
PM 4.1

LOCATION 3 SHEET 4
RANCHO CALIFORNIA RD
OC
PM 5.0

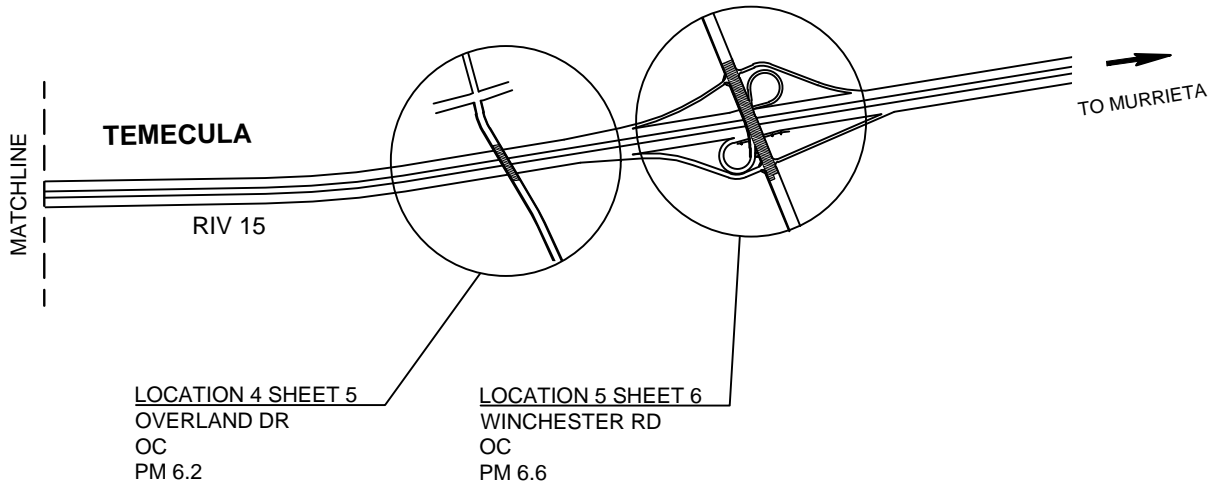
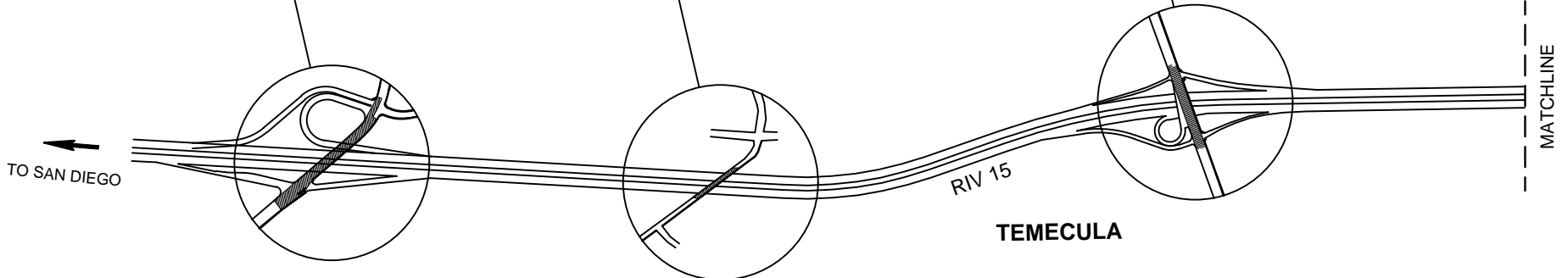
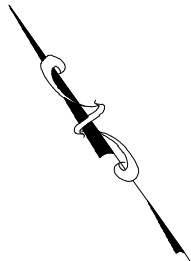
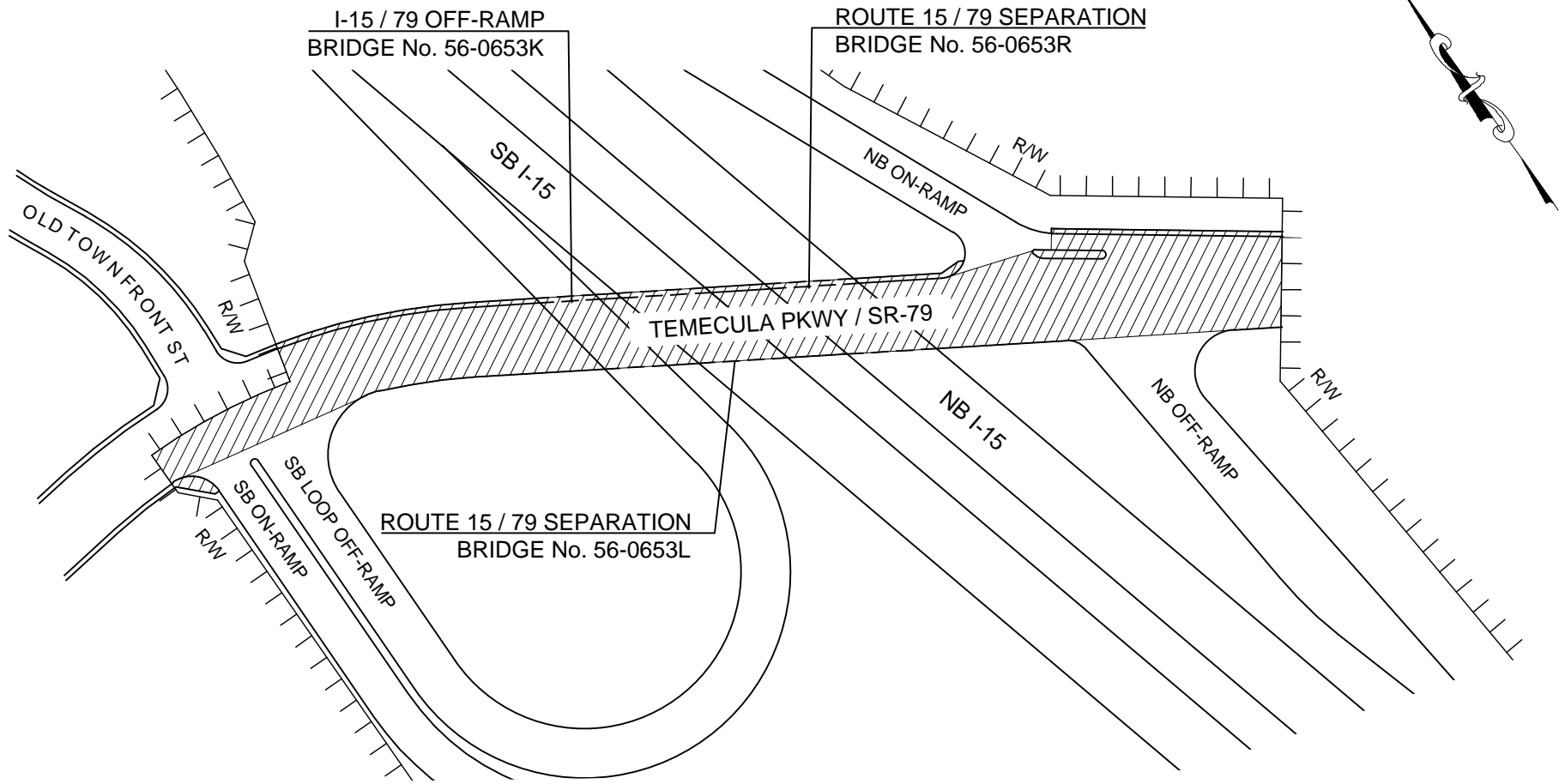





EXHIBIT "A"
NO SCALE

DIST	COUNTY	ROUTE	POST MILE	SHEET No.	TOTAL SHEETS
08	RIV	15	3.5	2	6



LEGEND

-  LOCAL ROAD SEGMENTS WITHIN FREEWAY R/W
-  LIMITS TO BE MAINTAINED BY CITY OF TEMECULA
-  STATE R/W

LOCATION 1: TEMECULA PKWY / SR-79



EXHIBIT "A"
NO SCALE

DIST	COUNTY	ROUTE	POST MILE	SHEET No.	TOTAL SHEETS
08	RIV	15	4.1	3	6

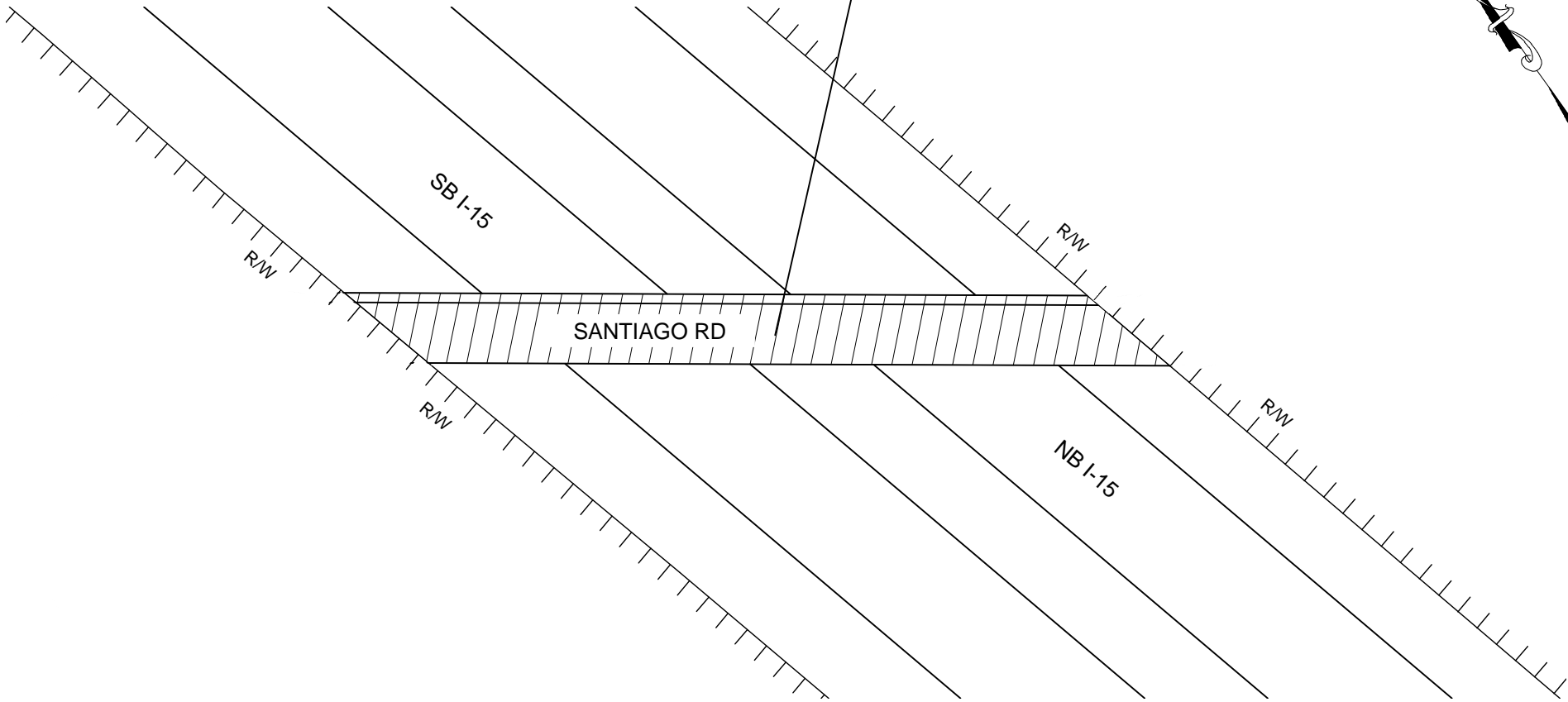
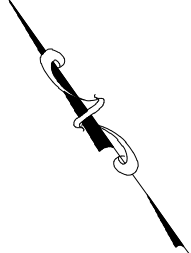
SANTIAGO RD OVERCROSSING
BRIDGE No. 56-0654



LEGEND

-  LOCAL ROAD SEGMENTS WITHIN FREEWAY R/W
-  LIMITS TO BE MAINTAINED BY CITY OF TEMECULA
-  STATE R/W



LOCATION 2: SANTIAGO RD OC

EXHIBIT "A"
NO SCALE

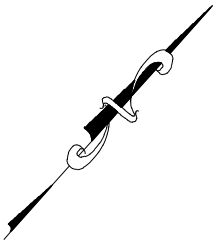
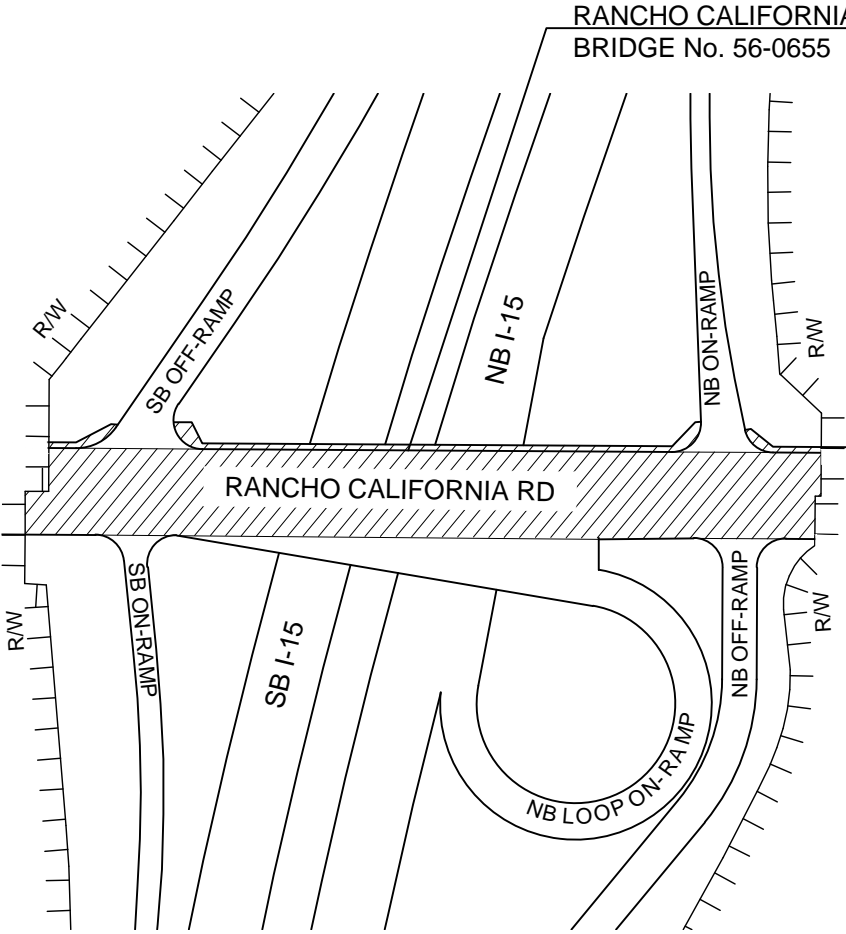
DIST	COUNTY	ROUTE	POST MILE	SHEET No.	TOTAL SHEETS
08	RIV	15	5.0	4	6



LEGEND

-  LOCAL ROAD SEGMENTS WITHIN FREEWAY R/W
-  LIMITS TO BE MAINTAINED BY CITY OF TEMECULA
-  STATE R/W



LOCATION 3: RANCHO CALIFORNIA RD OC

EXHIBIT "A"
NO SCALE

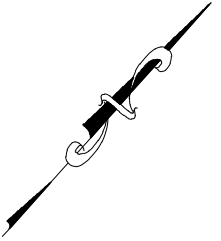
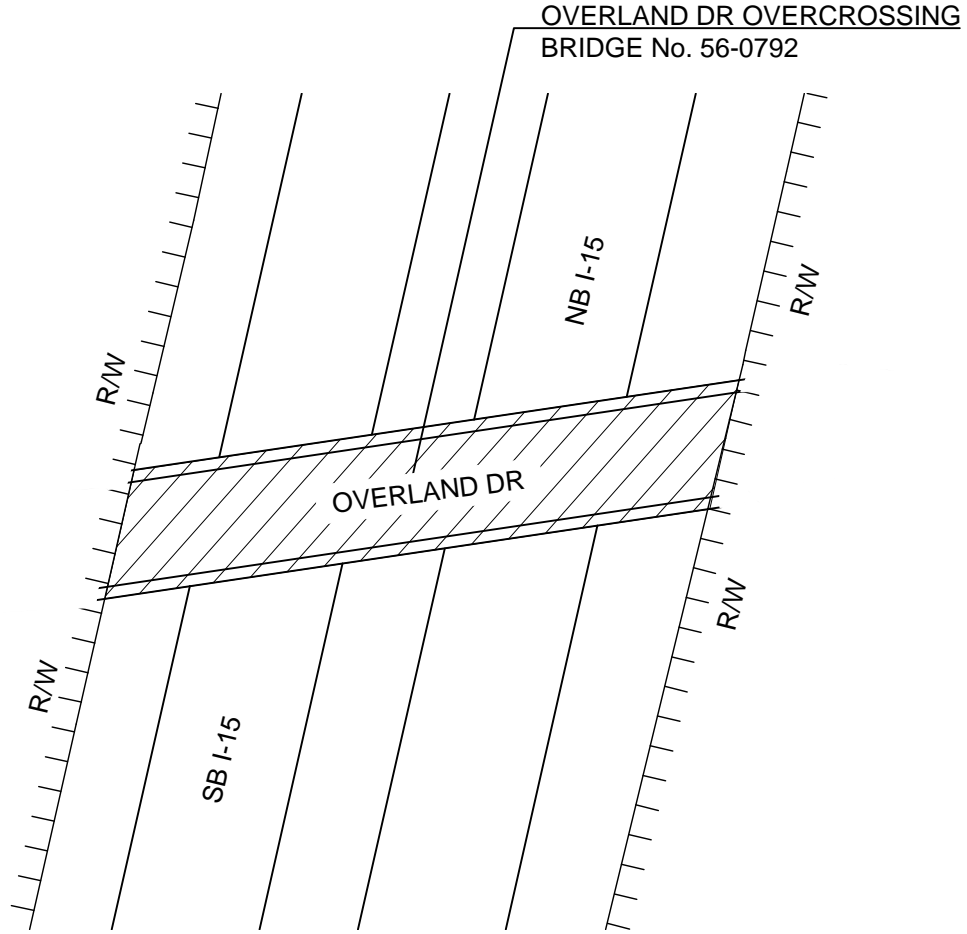
DIST	COUNTY	ROUTE	POST MILE	SHEET No.	TOTAL SHEETS
08	RIV	15	6.2	5	6



LEGEND

-  LOCAL ROAD SEGMENTS WITHIN FREEWAY R/W LIMITS TO BE MAINTAINED BY CITY OF TEMECULA
-  STATE R/W



LOCATION 4: OVERLAND DR OC

EXHIBIT "A"
NO SCALE

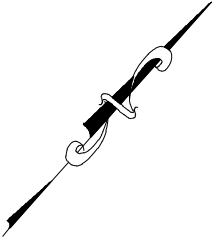
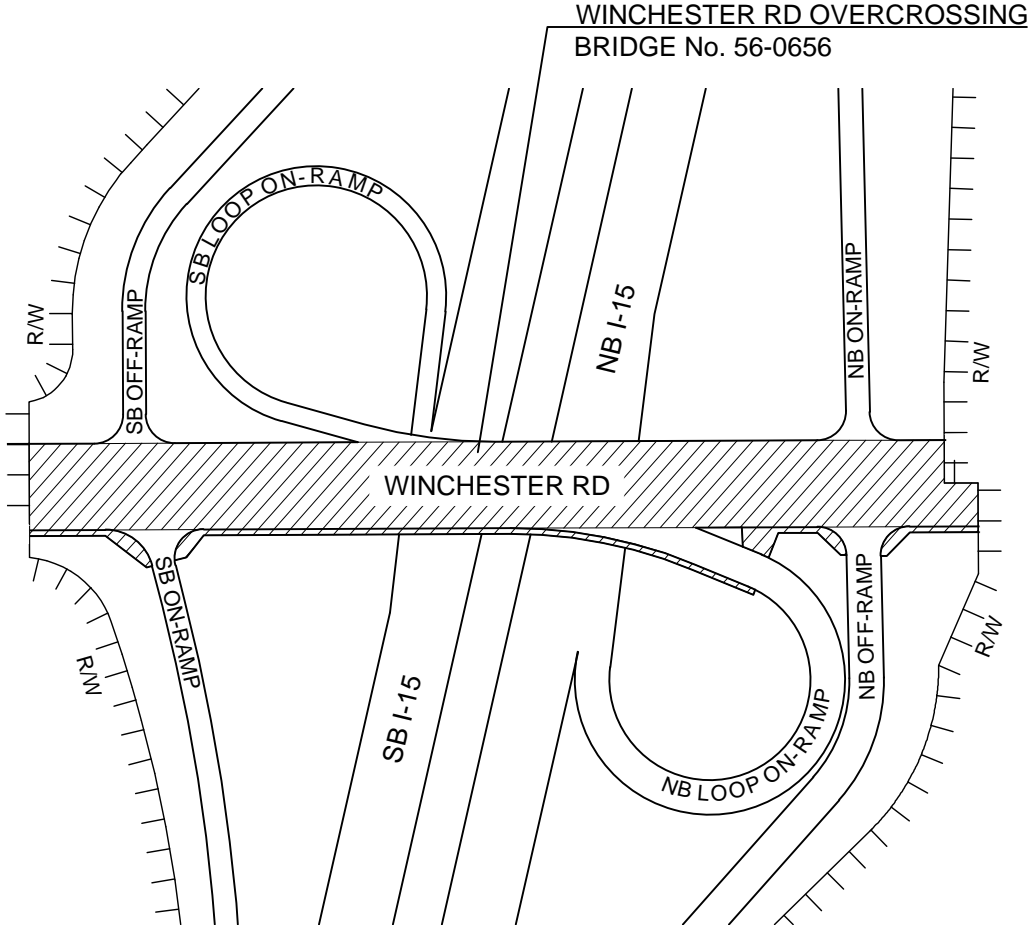
DIST	COUNTY	ROUTE	POST MILE	SHEET No.	TOTAL SHEETS
08	RIV	15	6.6	6	6



LEGEND

-  LOCAL ROAD SEGMENTS WITHIN FREEWAY R/W
-  LIMITS TO BE MAINTAINED BY CITY OF TEMECULA
-  STATE R/W

LOCATION 5: WINCHESTER RD OC

EXHIBIT "A"
NO SCALE